

Clarity Controls

HTA 300

AS

ENG

Code/Rev.: M139/23G
Date: 1/3/2011

Phone: +420 251 013 400
Fax: +420 251 013 401
clarity@dataapex.com
www.dataapex.com

DataApex Ltd.
Podohradská 1
155 00 Prague 5
The Czech Republic

Clarity[®], DataApex[®] and [®] are trademarks of DataApex Ltd. Microsoft[®] and Windows[™] are trademarks of Microsoft Corporation.
DataApex reserves the right to make changes to manuals without prior notice. Updated manuals can be downloaded from www.dataapex.com.

Author: DM

Contents

1 HTA 300 Control module	1
2 Requirements	2
3 Installation Procedure	3
3.1 Autosampler Setup - communication.....	3
3.1.1 Connections.....	4
3.2 Clarity Configuration.....	6
4 Using the control module	8
4.1 HT300A.....	9
4.1.1 Method Setup - AS - Basic & Washing.....	9
4.1.2 Method Setup - AS - Filling tab.....	11
4.1.3 Method Setup - AS - Internal standard & syncro.....	13
4.2 HT300L.....	15
4.2.1 Method Setup - AS - Basic tab.....	15
4.2.2 Method Setup - AS - Washing tab.....	17
4.2.3 Method Setup - AS - Derivatisation tab.....	19
4.3 Hardware Configuration.....	20
5 Sequence	21
5.1 Injection Modes.....	21
6 Troubleshooting	22

To facilitate the orientation in the **HTA 300** manual and **Clarity** chromatography station, different fonts are used throughout the manual. Meanings of these fonts are:

Instrument (blue text) marks the name of the window, to which the text refers.

Open File (italics) describes the commands and names of fields in **Clarity**, parameters that can be entered into them or a window or dialog name (when you already are in the topic describing the window).

WORK1 (capitals) indicates the name of the file and/or directory.

ACTIVE (capital italics) marks the state of the station or its part.

The bold text is sometimes also used for important parts of the text and the name of the **Clarity** station. Moreover, there are text sections written in format other than normal text. These sections are formatted as follows:

Note: Notifies the reader of possibly interesting information.

Caution: Warns the user of possibly dangerous or very important information.

█ Marks the problem statement or trouble question.

Description: Presents any closer information on the problem, describes its causes etc.

Solution: Marks the response to the question, presents a procedure how to remove it.

1 HTA 300 Control module

This manual describes the setting of **HT300A**, **HT300L**, **HT300LV**, **HT310A** and **HT310L** autosamplers. **HT300A** and **HT310A** are autosamplers for gas chromatography, while **HT300L** and **HT310L** are autosamplers for liquid chromatography and **HT300LV** is an autosampler supporting large sample volumes. **HT310A** and **HT310L** samplers have a fixed 10-vial trays that can not be upgraded to a full tray size, but are otherwise fully compatible with **HT300A** and **HT300L** autosamplers and unless stated otherwise in the text, all described settings and features apply equally to both 300 and 310 variants.

The control module enables direct control of the instrument over serial line. Direct control means that the autosampler can be completely controlled from the **Clarity** environment. Instrument method, controlling for example the vials and further device specific functions (e.g. washing), will be saved to the measured chromatograms.



Fig 1: HT300A autosampler

2 Requirements

- **Clarity** Installation CD ROM with AS Control module (p/n A26).
- Free serial port in the PC (fast - 16550 UART).

Note: Modern computers usually have only 1 (if any) serial (COM) port installed. To use more devices requiring the port, the **MultiCOM** adapter (p/n MC01) is available.

- Straight serial DB9F-DB9M cable (p/n SK02).

Note: Cables are not part of **Clarity** Control Module. It is strongly recommended to order required cables together with the Control Module.

Caution: The recommended firmware version in the autosampler is at least **3.21**. Otherwise it is not recommended to use the internal standard of the autosampler.

3 Installation Procedure

3.1 Autosampler Setup - communication

The autosampler communicates with PC using straight RS232-compliant DB9F-DB9M cable. When using 3-core cable, pins 7-8 must be connected on autosampler side.

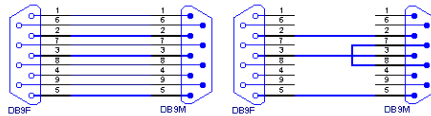

Fig 2: Serial cable DB9F-DB9M and 3-core cable

COM port settings on the PC side are:

9600, n, 8, 1

(as seen on [AS Status](#) dialog below, check only in case of problems with communication)

- Note:* If serial communication cannot be established and all parameters of communication are correctly set (speed, parity, etc.), then we recommend to remeasure the cable according to the **Fig 1** on pg 1. or **Fig 2** on pg 3. (especially pin connection 2 and 3).
- Note:* We supply 3m Serial cable DB9F - DB9M, but you can order longer, 3-core cable DB9F - DB9M.

3.1.1 Connections

Besides the serial RS-232 cable, following connections must be made to the **autosampler IN/OUT connector** (DB15F connector or DB9F at older pieces):

- The **ClarityStart (IN)** input must be connected to the autosampler **Inject output**.
- The **Clarity** active sequence **Ready signal (OUT)** output must be connected to the autosampler **Ready input** or the respective pins on HTA connector must be short-circuited.

The designations of pins are dependent on model number and are described in following tables:

Tab 1: HT300A - designations of pins

Connection	Clarity cable	9-pin connector (old models)	PIN	15-pin connector (*)	PIN
Start	IN (red)	SMP_inst	3	SAMPINS_NO	3
	IN (shield)	GNDGC	5	SAMPINS_COM	6
				SAMPINS_NC	15
Ready	OUT(red)			GC_Ready NON	9
			6	GC_READY	4
	OUT (shield)	GNDGC	5	GND	5

Relay contact: NC = norm. closed, NO = norm. open, COM = common contact

(*) = New models above S/N 10300.

Tab 2: HT300L and HT300LV - designations of pins

Connection	Clarity cable	9-pin connector (old models)	PIN	15-pin connector (*)	PIN
Start	IN (red)	SMP_inst	3	SAMPINS_NO	3
	IN (shield)	GNDGC	5	SAMPINS_COM	6
Ready	OUT (red)	GC_Ready	6	GC_READY	9
	OUT (shield)	GNDGC	5	GND 5	5

(*) New models above S/N 10300.

Refer to manual manual for description of cables supplied with the autosampler.

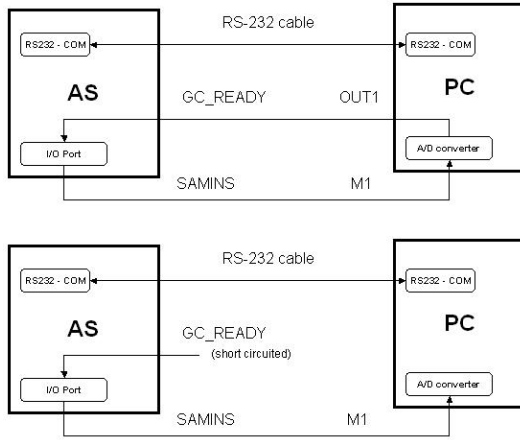

Fig 3: HTA 300 scheme of connection

3.2 Clarity Configuration

- In the [System Configuration](#) dialog press the *Add* button to invoke the [Available Control Modules](#) dialog.

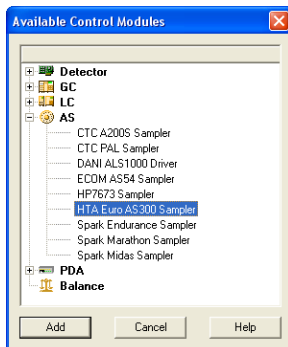

Fig 4: Available Control Modules

- Select the **HTA300A** Sampler and press the *Add* button.
- The [HTA AS 300 Setup](#) dialog will appear.

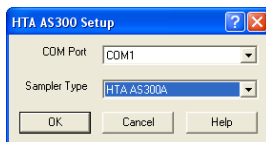

Fig 5: HTA AS 300 Setup

- Fill in the *COM Port* and *Sampler Type* fields and press the *OK* button.

Choose **HTA AS 300A** as sampler type for both **HT300A** and **HT310A** that are described in this manual.

Choose **HTA AS 300L** or **HTA AS 300LV** as sampler type according to the type of sampler you have.

The **HTA 300** Sampler will appear in the *Setup Control Modules* list of the [System Configuration](#) dialog.

- Drag the sampler icon from the *Setup Control Modules* list on the left side to the desired *Instrument* tab on the right side.

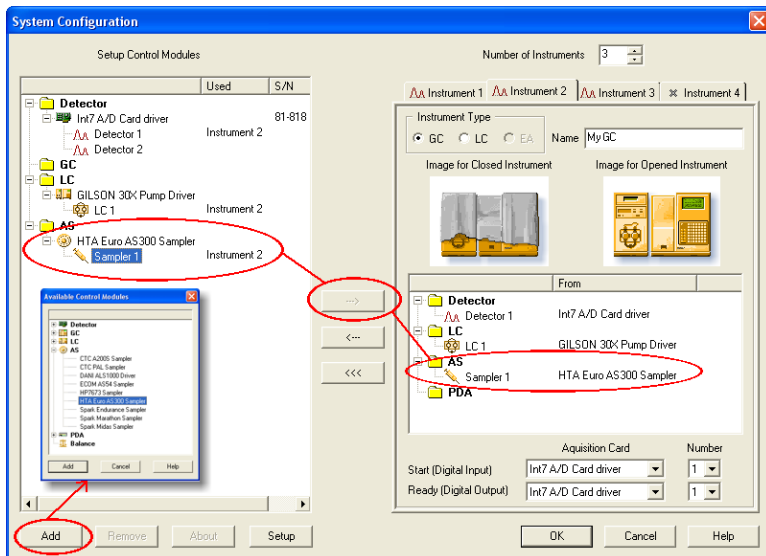

Fig 6: System Configuration

Set the *Start* and *Ready* input and output numbers for your acquisition card according to the wires used for synchronization.

4 Using the control module

In the [Method Setup](#) dialog of the instrument with assigned autosampler a new [Method Setup - AS](#) tab will appear..

The *From AS* and *To AS* buttons serve for transfer of methods from and to autosampler.

Caution: If you have injection methods already established in the sampler, it is advisable to download them to **Clarity** using the *From AS* button and save them as a **Clarity** method.

The *AS Status* button displays the [AS Status](#) dialog.

Parameter ranges and precisions

HT300L

All volumes are set in μl with precision of $\pm 0,01 \mu\text{l}$ (or $\pm 0,1 \mu\text{l}$ for volumes bigger than $10 \mu\text{l}$ respectively) and ranging from 0 to $500 \mu\text{l}$. Valid volume range also depends on mounted syringe.

Speeds are set in $\mu\text{l/s}$ with precision of $\pm 0,01 \mu\text{l/s}$ (or $\pm 0,1 \mu\text{l/s}$ for speed greater than $10 \mu\text{l/s}$) in range $1 - 100 \mu\text{l/s}$.

HT300LV

All volumes are set in μl with precision of $\pm 1 \mu\text{l}$ and ranging from 0 to $10000 \mu\text{l}$ (10 ml). Valid volume range also depends on mounted syringe.

Speeds are set in $\mu\text{l/s}$ with precision of $\pm 1 \mu\text{l/s}$ in range $100 - 10000 \mu\text{l/s}$ (10 ml/s). The *AS Status* button displays the [AS Status](#) dialog.

The *AS Status* button displays the [AS Status](#) dialog.

4.1 HT300A

4.1.1 Method Setup - AS - Basic & Washing

Basic and washing parameters of the method.

All volumes are set in μl with precision of $\pm 0,01 \mu\text{l}$ (or $\pm 0,1 \mu\text{l}$ for volumes bigger than $10 \mu\text{l}$ respectively) and ranging from 0 to $500 \mu\text{l}$.

Speeds are set in $\mu\text{l/s}$ with precision of $\pm 0,01 \mu\text{l/s}$ (or $\pm 0,1 \mu\text{l/s}$ for speed greater than $10 \mu\text{l/s}$) in range $1 - 100 \mu\text{l/s}$.

Fig 7: Method Setup - AS - Basic & Washing

Method No.

Internal method number under which the method is stored in sampler; when reading method from sampler current number is used, methods saved into sampler remain there even after closing **Clarity**.

Range: 0 - 9

Sample Wash Cycles

Number of times the system should be flushed with sample (rather than solvent) prior to injection.

Prewash / Postwash

Parameters are set up separately for washing prior to *Prewash* and after *Postwash* injection.

Solvent

Solvent is placed in one of four special vials marked A - D.

Wash Mode

Sets washing mode. Can be one of Injection - pre/post every injection, Sample - pre/post every sample and Step - pre/post every sequence step.

Wash Volume

Volume of washing solvent in μl

Wash Cycles

Number of washes

4.1.2 Method Setup - AS - Filling tab

Volume and speed settings.

All the volumes are set in μl with precision of $\pm 0,01 \mu\text{l}$ (or $\pm 0,1 \mu\text{l}$ for volumes bigger than $10 \mu\text{l}$ respectively) and ranging from 0 to 500 μl . Speeds are set in $\mu\text{l/s}$ with precision of $\pm 0,01 \mu\text{l/s}$ (or $\pm 0,1 \mu\text{l/s}$ for speed greater than $10 \mu\text{l/s}$) in range 1 - 100 $\mu\text{l/s}$.

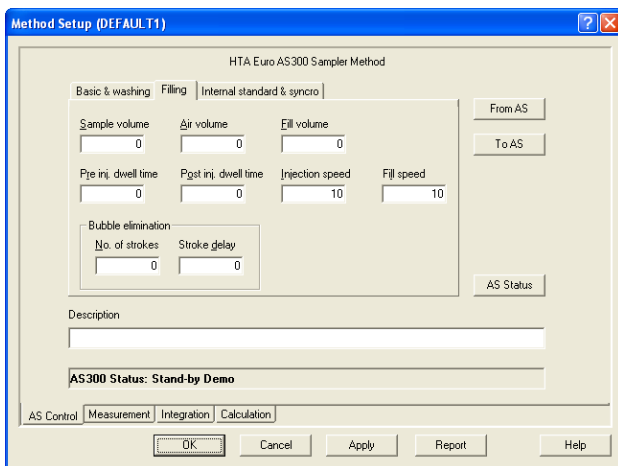

Fig 8: Method Setup - AS - Filling

Sample Volume

Volume of sample to be injected

Air Volume

Volume of air to be injected with sample

Fill Volume

When internal standard is NOT used, syringe can be washed with sample rather than with solvent. This parameter sets sample-washing volume (set *Sample wash cycles* on **Basic & washing** page too).

Pre and post injection dwell time

Time (in seconds ranging 0 - 99 s) during which the needle remains in injector prior and post injection - used for temperature leveling

Injection Speed

Speed of sample injection

Fill Speed

Speed of sample aspiration

No. of strokes

Number of pull-up strokes of the plunger (0 - 15) prior to sample aspiration - useful for bubble removal

Stroke Delay

The time (in s, 0 - 15) the syringe stays in sample after aspiration - useful for viscous samples

4.1.3 Method Setup - AS - Internal standard & syncro

Determines when injection starts:

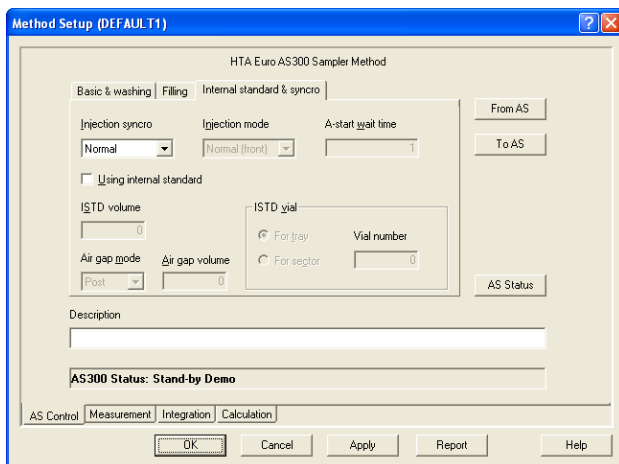

Fig 9: Method Setup - AS - Internal standard & syncro

Injection syncro

The *Injection syncro* field, together with the *Injection mode* and *A-start wait time* fields, govern the synchronization of injections.

Tab 3: Injection syncro options

Synchronization	Output signal to GC	Start injection (signal from GC)
Normal	At the beginning of the syringe plunger movement	At the reception of the GC Ready signal
Twin (trigger)	At the beginning of the syringe plunger movement	At the reception of the signal GC Ready it starts collecting; then, it waits for an external synchronism (SYNC-IN) to continue with the injection
A-start	When sensor touches the injector	At the reception of the GC Ready signal
Delayed	At the end of the syringe plunger movement	At the reception of the GC Ready signal

When A-Start syncro method is used also the parameter Syncro A-Start wait time can be specified; it is the time sampler waits prior to injection; time is set in seconds

Range 0 - 25,5 s in steps 0,1 s

When two injectors are configured, parameter Injection mode can be specified to one of following values:

- *Normal (front)* - injection into the front injector; this is the default for one injector
- *Rear* - injection into the rear injector
- *Confirmation* - injection of one sample into both injectors
- *High throughput* - injection of different samples into both injectors

The AS 300 autosampler allows for mixing sample and the internal standard during injection. This function is configured with following parameters:

Using internal standard

Whether use internal standard at all

ISTD volume

The volume of internal standard, values are again in μl with precision of $\pm 0,01 \mu\text{l}$ ($\pm 0,1 \mu\text{l}$ for volumes bigger than $10 \mu\text{l}$ respectively) ranging 0 - $500 \mu\text{l}$

Air gap mode

Method of separation of sample and internal standard in syringe with an air bubble; allowed values are **Post** - there is only one bubble in between sample and ISTD - and **Double** - there is one bubble on each side of the sample

Air gap volume

Volume of the air bubble

ISTD vial

ISTD vial placement; can be specified either as position for whole tray or within sector where the current sample vial is (only for trays with sectors)

4.2 HT300L

4.2.1 Method Setup - AS - Basic tab

Basic parameters of the method.

The screenshot shows the 'Method Setup DEFAULT1' dialog box for the 'HTA AS300 Sampler Method'. The 'Basic' tab is selected. The 'Method No.' is set to 2. The 'Analysis time' is 2 hours and 30 minutes. The 'Sample Volume' is 2, 'Pullup Strokes' is 0, and 'Fill Speed' is 10. The 'Viscosity Delay (s)' is 0, 'Pullup Volume' is 0, and 'Injection Speed' is 10. There are buttons for 'From AS', 'To AS', and 'AS Status'. A 'Description' field is empty. The 'AS300 Status' is 'Stand-by Demo'. At the bottom, there are tabs for 'AS Control', 'Measurement', 'Acquisition', 'Integration', and 'Calculation', and buttons for 'OK', 'Cancel', 'Apply', 'Report', and 'Help'.

Fig 10: Method Setup - AS - Basic

Method No.

Internal method number ranging 0-9 under which the method is stored in sampler; when reading method from sampler current number is used, methods saved into sampler remain there even after closing the **Clarity** station.

Analysis Time

The time the HPLC analysis will take in hours and minutes. This is necessary to make sure the injections are made at the correct time. Valid values are 0-23 hours and 0-59 minutes.

Sample Volume

Volume of sample to be injected

Note: The *Sample Volume* field is used only in Single Run injections.

Pullup Strokes

Number of pullup strokes of the plunger (0 - 15) prior to sample aspiration - useful for bubble removal

Fill Speed

Speed of sample aspiration

Viscosity Delay

The time (in s, 0 - 15) the syringe stays in sample after aspiration - useful for viscous samples

Pullup Volume

Volume of each of the pullup strokes

Injection Speed

Speed of sample injection

4.2.2 Method Setup - AS - Washing tab

Syringe washing parameters of the method. Parameters are set up separately for washing prior to (**Prewash**) and after (**Postwash**) injection:

The screenshot shows the 'Method Setup DEFAULT1' dialog box for the 'HTA AS300 Sampler Method'. The 'Washing' tab is active. The parameters are as follows:

Parameter	Value	Mode	Solvent
Prewash Cycles	0	Injection	A
Prewash Volume	0		
Loop Wash Cycles	0		
Loop Wash Vol.	0		
Sample W. Cycles	0		
Sample Wash Vol.	0		
Postwash Cycles	0	Injection	A
Postwash Volume	0		

Additional options include 'From AS', 'To AS', 'AS Status', and a 'Flush Loop As Well' checkbox. The 'AS300 Status' is 'Stand-by Demo'. The bottom of the dialog has tabs for 'AS Control', 'Measurement', 'Acquisition', 'Integration', and 'Calculation', along with 'OK', 'Cancel', 'Apply', 'Report', and 'Help' buttons.

Fig 11: Method Setup - AS - Washing

Wash Cycles

Number of washes

Wash Volume

Volume of washing solvent in μl

Wash Mode

Sets washing mode. Can be one of:

- **Injection** - pre/post every injection,
- **Sample** - pre/post every sample and
- **Step** - pre/post every sequence step.

Solvent

Solvent is placed in one of four special vials marked A - D.

Loop Wash Cycles

Number of times the loop should be washed. Prewash solvent is used for flushing the loop.

Loop Wash Volume

Volume of washing solvent in μl

Sample Wash Cycles

Number of times the system should be flushed with sample (rather than solvent) prior to injection

Sample Wash Volume

Volume of washing solvent in μl

Flush Loop As Well

When this check box is set, loop is washed with the sample after washing the syringe, otherwise syringe is discharged into the waste vial.

4.2.3 Method Setup - AS - Derivatisation tab

Fig 12: Method Setup - AS - Derivatisation

Derivatisation parameters are set on the last page (this feature can be used for dilutions or internal standard as well):

Using Derivatising Agent

Whether use derivatisation at all

Derivatisation Cycles

How many times should be the sample injected with derivatising agent

Derivatisation Time

The time the unit will leave injected derivatising solution in vial prior to aspiration.

Derivatising Agent Vial

Derivatising agent vial placement; can be specified either as position for whole tray or within sector where the current sample vial is from (only for trays You can also use solvent vials **A-D** for derivatising agent.

Extended (P) positions on 110-vials tray can be specified either as 0P-9P or by number 100-109, solvent vials can be specified as A-D or 110-113.

4.3 Hardware Configuration

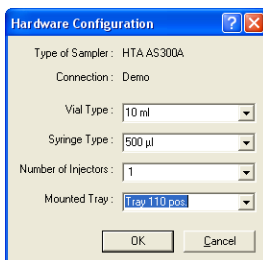

Fig 13: Hardware Configuration

In the full version, this dialog displays automatically detected communication port settings and some parameters of the sampler, like vial and syringe type, number of injectors and tray size.

Note: In demo version parameters can be set according to real possibilities of the sampler, which means there are three sizes of vials from 2 to 10 ml, eight sizes of syringe ranging from 1 to 500 µl single or twin injectors and tray for 10, 40 or 110 vials.

5 Sequence

5.1 Injection Modes

The autosampler allows for partial or full loop injections. The user must observe for correct injection volumes with respect to installed loop size - for partial loopfill maximum of 50% loop volume is recommended, for full loop injection at least 200-300% of loop volume should be injected. Checking for valid volumes is neither performed by the sampler nor by the software.

6 Troubleshooting

When the remedy for some problem cannot be discovered easily, the recording of communication between **Clarity** and the autosampler can significantly help the **DataApex** support to discover the cause of the problem.

The recording can be enabled by adding or amending the COMMDRV.INI file in the **Clarity** installation directory (C:/CLARITY by default). The file can be edited in any text editor (e.g. Notepad). Following section should be edited or added:

```
[COM1]
echo=on
textmode=on
filename=HTA300.txt; %D or %d could be used to include a current
date (recommended in combination with the Reset=Off option
reset=off
```

Note: The created *.TXT files will greatly help in diagnosis of unrecognized errors and problems in communication.